



4/2026 Life to Eagle

**For Eagle Scout Candidates,
Unit Leaders and
Parents/Guardians**

***Blue Hen District
Del-Mar-Va Council***

Dan White, Andy Sensing - Eagle Board Chairs



This document is for reference only and subject to change. Review the most updated documents on the official Scouting America websites for current information.



Today's Objectives

- ✿ **Eagle Feathers**
- ✿ **Eagle Scout Rank Requirements**
- ✿ **Eagle Scout Service Project**
- ✿ **Eagle Scout Rank Application**



Session Goals

Objectives

- 🦅 to inspire you to take action!
- 🦅 to learn the Life to Eagle Process
- 🦅 to learn how to start and complete your Eagle Project
- 🦅 to learn what documentation must be submitted for Eagle Rank consideration



Eagle Feathers



- ❖ **The Rank of Eagle tells others about**
 - ❖ **OUR Character**
 - ❖ **Skill**
 - ❖ **Leadership ability**
- ❖ **The Rank of Eagle is time limited - Beware the 4 G's**
 - ❖ **Grades – Gas – Games – Girls/Guys ... Plus Jobs and Sports**
- ❖ **The Eagle rank is also a serious consideration for college entrance accomplishments and military recruiters.**



Significance of the Eagle Scout Rank

- ✿ **The average age of Scouts earning the Eagle Scout rank is 17.3 years of age**
- ✿ **Over 8.5 million hours of work on projects**
- ✿ **About 3,000,000 Eagle Scouts since 1912**
- ✿ **In 1912, there were 23 Eagles. There were only 5 merit badges required (Athletics, First Aid, Life Saving, Personal Health, Public Health).**
- ✿ **About 3% of all eligible Scouts since 1912**



Be Aware.....

NO Council, District, Unit or Individual
has the authority to **ADD** to or **SUBTRACT**
from any BSA advancement requirement.



To Achieve the Eagle Scout Rank a Scout Must

- ✿ **Earn six prior Scouting Ranks**
- ✿ **Meet about 55 achievement requirements**
- ✿ **Satisfactorily complete several hundred tasks**
- ✿ **Be reviewed by Adult Scouters at the Unit, District, Council and National level dozens of times**





Steps to Eagle

In order to advance to the rank of Eagle, a candidate must complete all requirements:

- 1. Active participation**
- 2. Scout principles and spirit**
- 3. Merit badges**
- 4. Positions of responsibility**
- 5. While a Life Scout, plan, develop, and provide leadership to others in a service project**
- 6. Scoutmaster conference**
- 7. Board of Review**



Requirement 1. Participation

Be active in your troop, crew, or ship for a period of at least six months after you have achieved the rank of Life Scout.

 **Mastery of Scouting skills & personal character growth cannot happen without participation.**

 **Participation goals may vary from unit to unit.**





Requirement 1. Participation

Since we prepare young people to go forth, and essentially, make a positive difference in our American society, we judge that a member is “active” when his/her level of activity in Scouting, whether high or minimal, has had a sufficiently positive influence toward this end.

1. The Scout is registered.
2. The Scout is in good standing.
3. The Scout meets the unit’s reasonable expectations, or, if not, a lesser level of activity is explained.

If a Scout has fallen below their unit’s activity-oriented expectations, then it must be due to other positive endeavors—in or out of Scouting—or to noteworthy circumstances that have prevented a higher level of participation. In this case a Scout is considered “active” if a Board of Review can agree that Scouting values have already taken hold and been exhibited.



Requirement 2. Scout Spirit

As a Life Scout, demonstrate that you live by the principles of the Scout Oath and Scout Law in your everyday life and tell how you have done your duty to God. List the names of individuals who know you personally and would be willing to provide a recommendation on your behalf.

- ❖ Scouting ideals are reflected in the character of an Eagle.**
- ❖ He or she sets the example, not only in the Scouting setting, but in every facet of their life.**



Requirement 2.

Letters of Recommendation

- ✿ **You will list these on your *Eagle Scout Rank Application*.**
- ✿ **You will ask these people to write letters of recommendation to be submitted to your Eagle Board of Review.**
- ✿ **Requested references should be sent to a designated unit leader (SM or AC) in advance of the Eagle Board of Review.**



Requirement 3. Skills

**Earn a total of 21 merit badges (13 required badges).
List the month, day, & year the merit badge was earned.**

The Merit Badge Program promotes:

- ✿ **Basic character-developing tools**
- ✿ **Opportunity to learn career skills**
- ✿ **Develop physical fitness...**
- ✿ **Hobbies and interests for a lifetime**
- ✿ **Contact with adults with whom you may not be acquainted**
- ✿ **All requirements must be completed prior to 18th b-day**
- ✿ **Eagle application dates must match Council Records**





Requirement 3. Merit Badges

- **These 13 are the merit badges required for the Eagle rank. There are also 8 elective merit badges.**
- **The Citizenship in Society merit badge is discontinued as of 2/27/2026.**
- **Those that started working on Citizenship in Society merit badge before 2/27/2026 can continue but must complete it before 12/31/2026.**

- Camping**
- Citizenship in the Community**
- Citizenship in the Nation**
- Citizenship in the World**
- Citizenship in Society****
- Cooking**
- Communications**
- Personal Fitness**
- Emergency Preparedness OR Lifesaving**
- Environmental Science OR Sustainability**
- Family Life**
- First Aid**
- Personal Management**
- Swimming OR Hiking OR Cycling**





Requirement 4. Leadership

While a Life Scout, serve actively for a period of six months in one or more of the following positions of responsibility.

- ✿ **May be elected by peers or assigned by the Scoutmaster**
- ✿ **6 Months is the MINIMUM, more than one position may be held**
- ✿ **On the Eagle Application list only positions held while a Life Scout**
- ✿ **Serve Actively means: Must do the job - Not just wear the patch**
- ✿ **Approved troop positions are:** (Venturing Crew- Check latest Eagle Scout Application)

Senior Patrol Leader	Troop Scribe	Patrol Leader	Instructor
Asst. Senior Patrol Leader	Troop Librarian	Chaplain aide	OA Rep
Jr Asst. Scoutmaster	Troop Historian	Den Chief	Troop Guide
Outdoor Ethics Guide	Webmaster	Troop Quartermaster	
- ✿ **The Scoutmaster may assign a special leadership project in place of a Position of Responsibility - for Star and Life, NOT for Eagle.**



Requirement 5. ESSP

While a Life Scout, **plan, develop, and give leadership to others in a service project** helpful to any religious institution, any school, or your community. (The project must benefit an organization other than the BSA.) A project proposal must be approved by the organization benefiting from the effort, your unit leader and unit committee, and the council or district before you start. **You must use the Eagle Scout Workbook (latest version 2023a – 2/23), in meeting this requirement. (To learn more about the Eagle Scout service project, see the *Guide to Advancement*, section 9)**

- ✿ **Demonstrating PLANNING & LEADERSHIP, through service, is *still* the objective.**
 - ✿ **The Scout: Plans, Develops, and Leads others....**
 - ✿ **The Unit: Provides mentorship so that the Scout can do his very best at planning and executing this requirement.**
 - ✿ **The District: Reviews the ESSP Proposal for Community Benefit, Leadership Opportunity commensurate with the rank of Eagle Scout, and the candidate's understanding of further planning. Approves the proposal when it is ready.**
- All of the Scouting methods, training, experience, and YOUR skill are being “tested” by this requirement.**



Eagle Scout Service Project

- ❖ **Cannot be routine labor or benefit a commercial business. Must have opportunity for Planning, Development and Leadership.**
- ❖ **Must benefit religious institute, any school, charity, or your community. NOT Scouting America**
- ❖ **May NOT be a “fund raiser”**
 - ❖ **Fund-raising is permitted only for securing materials needed to carry out the project.**
 - ❖ **Donors to projects must be made aware of what entity is benefiting from the project, and that it clearly is not Scouting America.**
 - ❖ **Any funds raised for a project and not used for the purchase of project materials must go to the beneficiary.**
 - ❖ **A Scout is thrifty... they help to pay their own way**
- ❖ **Must be planned and carried out by one Scout - no joint projects**
- ❖ **Can take 3-12 months to complete - plan ahead! **A key lesson most candidates learn is that they can't control other people's schedules****
- ❖ **Must take place while a Life Scout**



ESSP - Overall Process

- ✦ **Generate 2-3 possible ideas (internet, previous projects, leaders, interest or passion of Scout, religious organization, troop sponsor)**
- ✦ **Discuss ideas with your Unit Leader, Coach, Mentor, and Beneficiary Rep**
- ✦ **Consider Leadership Opportunity, Community Value and Project Scope**
- ✦ **Obtain initial approval from Unit Leadership & Beneficiary**
- ✦ **Put together a project PROPOSAL**
- ✦ **Detail planning is not necessary prior to approval**
- ✦ **Must use most recent official ESSP Workbook (02/2023 latest) (not compatible with Chromebook OS).**
- ✦ **Obtain Approvals: THE CANDIDATE SIGNS COMMITMENT**
 - 1) Unit Leader, 2) Unit Committee, 3) Beneficiary
 - 4) District Advancement Committee (last, email to Eagle Board Chair, Dan White - 70Eagle279@gmail.com or Andy Sensing – asensing@aol.com)
- ✦ **Develop the detail plan**
- ✦ **Submit plan to approvers for review (not additional approval)**
- ✦ **Execute the Plan**
- ✦ **Record Changes & Complete ESSP Workbook**



ESSP – *Beneficiary approval!!!

- ✦ **Prior to selecting your project make sure to find a beneficiary you can work with and will provide the guidance you will need on what they are looking for.**
- ✦ **Make sure the person you are working with can make decisions on the behalf of the beneficiary organization. You cannot begin work until the beneficiary signs off on your project.**
- ✦ **Communication with the beneficiary should be maintained at all times to make sure your work and the beneficiary's visions are aligned. Also make sure that you avoid "project creep". Stick to the approved plan. If the beneficiary requests additional work it must be in the scope of the project.**
- ✦ **If your project deviates significantly from your plan, you will need to consult your Troop leadership and potentially the District Eagle Board Chair.**



Eagle Scout Service Project

After completion

Before You start

- **Project Concept**
- **Project Proposal**
- **Approval**
- **What?**
- **Who?**
- **Where?**
- **Why?**
- **When?**
- **How?**
- **Project Final Plan**

Carrying out the project

- **Project Plan**
- **Record Progress of Project:**
 - Hours
 - Materials
 - Changes
 - Photos
 - Leadership

- **Service Project Report**
- **Approvals of Completed Project**
- **Project & Board of Review**



ESSP - Writing the Proposal

Overview

- ✦ **First step in Project**
- ✦ **Use the February 2023 (or most current version) ESSPW #2023a - Instructions are on Page 3-4 (Read the entire workbook)**
- ✦ **Must show:**
 - ✦ **Provides sufficient opportunity to meet the Eagle Scout service project requirements. (Planning, development and leadership opportunity)**
 - ✦ **It appears to be feasible (Realistic but challenging for the rank of Eagle)**
 - ✦ **Safety issues are considered. (Possible safety concerns and guard against injury and what to do if someone gets hurt – Guide for Safe Scouting!)**
 - ✦ **Key phases and steps required to complete final detailed plan**
 - ✦ **Action steps for further detailed planning are included.**
 - ✦ **You are on the right track with a reasonable chance for a positive experience and can meet your timeframe**
 - ✦ **NO work can be done on the project, fundraising or donations until the project is approved!!!**

Be Prepared and Time Management are critical



ESSP – Contact Page

Proposal page B

Contact Information

This needs to be completely filled out – Just like a job application

If not applicable – write N/A

District will not review proposal if this page is incomplete.

Council Contact is: Carol Swank, Delmarva Council, 1910 Baden Powell Way, Dover DE 19904

Contact Information

Eagle Scout candidates should know who is involved, but contact information may be more important to unit leaders, unit committees, project beneficiaries, and council or district approval representatives in case they want to talk to one another. While it is recognized that not all the information will be needed for every project, Scouts are expected to provide as much as reasonably possible. Approval representatives must understand, however, that doing so is not part of the service project requirement.

Eagle Scout Candidate

Name:		Birth date:	
Email address:		BSA PID number*:	
Address:	City:	State:	Zip:
Preferred telephone(s):		Life board of review date:	

*BSA PID No., found on the BSA membership card

Current Unit Information

Check one:	<input type="checkbox"/> Troop	<input type="checkbox"/> Team	<input type="checkbox"/> Crew	<input type="checkbox"/> Ship	Unit Number:
Name of District:					Name of Council:

Unit Leader Check one: Scoutmaster Varsity Coach Crew Advisor Skipper

Name:	Preferred telephone(s):
Address:	City: State: Zip:
Email address:	

Unit Committee Chair

Name:	Preferred telephone(s):
Address:	City: State: Zip:
Email address:	

Unit Advancement Coordinator (If your unit has one)

Name:	Preferred telephone(s):
Address:	City: State: Zip:
Email address:	

Project Beneficiary (Name of religious institution, school, or community)

Name:	Preferred telephone(s):
Address:	City: State: Zip:
Email address:	

Project Beneficiary Representative (Name of contact person for the project beneficiary)

Name:	Preferred telephone(s):
Address:	City: State: Zip:
Email address:	

Your Council Service Center

Council name:	Preferred telephone(s):
Address:	City: State: Zip:

Council or District Project Approval Representative (Your unit leader, unit advancement coordinator, or council or district advancement chair may help you learn who this will be.)

Name:	Preferred telephone(s):
Address:	City: State: Zip:
Email address:	

Project Coach (Your council or district project approval representative may help you learn who this will be.)

Name:	Preferred telephone(s):
Address:	City: State: Zip:
Email address:	



ESSP – Project Description

- ❖ **Project Description and Benefit (MOST IMPORTANT to get this right)**
 - ❖ **Succinct description of project goal(s) and scope. Describe the work process to be used to complete the project and leadership skills to be employed.**
 - ❖ **Include sizes, numbers, dimensions, etc. to help define the scope of the project.**
 - ❖ **Explain the benefit, including the number of people to be affected, and a description of the current condition.**
 - ❖ **How long will it take and how many people will you lead?**
- ❖ **Drawings, Photos, Google view and documents (a must for any area planning)**
 - ❖ **These are included as extra documents with the proposal document. They will not be embedded into the workbook.**
 - ❖ **Include a caption that explains the photo or drawing**
 - ❖ **Include photos of current condition or where the new item will be located.**
 - ❖ **Give credit to drawings or plans created by others.**
- ❖ **Check grammar and spelling – this is the capstone of your Scouting journey, show your best!**



ESSP—Establish the Vision

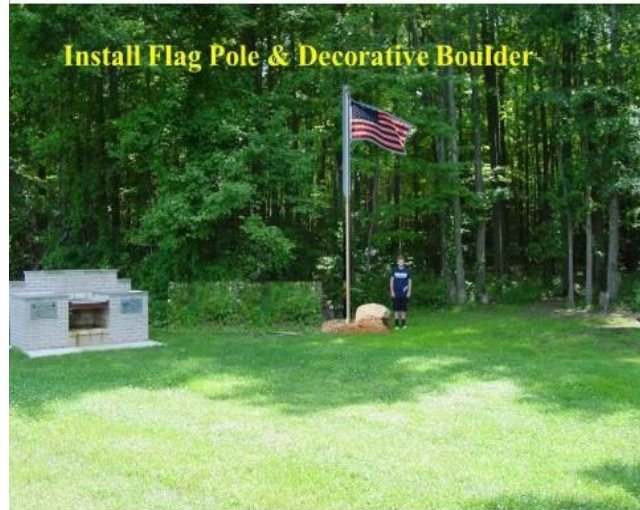

Install Flag Pole & Decorative Boulder

Proposed location of flag pole and memorial stone.



The rotting bases under the benches will be replaced.



"Trail of Angels" Sign to Mark Hiking Trail

Example of how "Trail of Angels" sign will look.



Relocate Wood Pile & Construct Storage Shed

A new storage structure for the firewood will be constructed near the fire ring.



ESSP—Establish the Vision

Examples of other drawings, plans and aerial photos

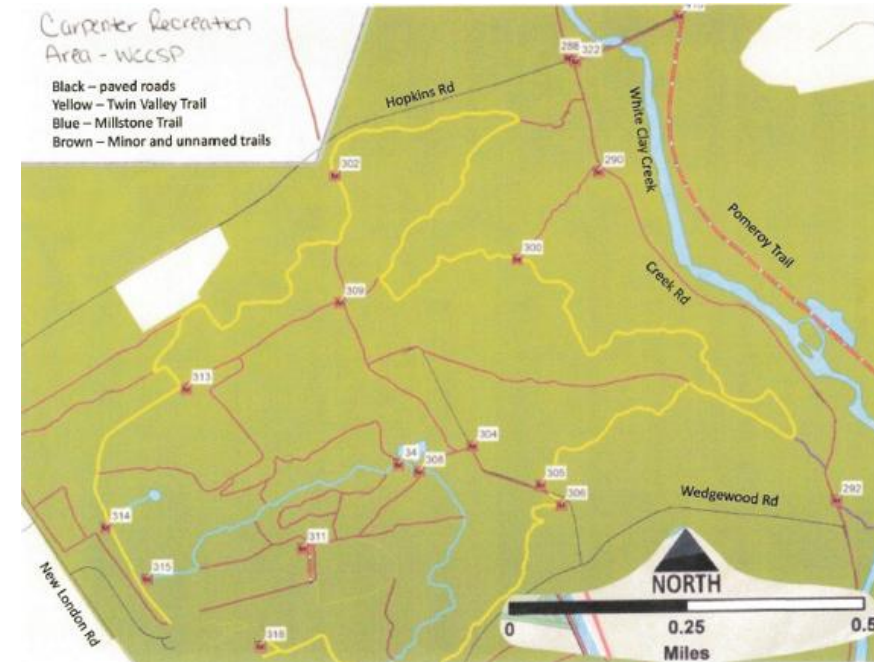
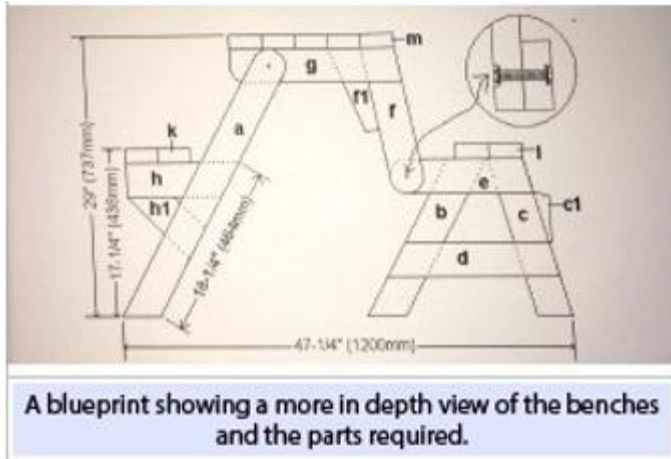

Map with locations of 17 new trail markers

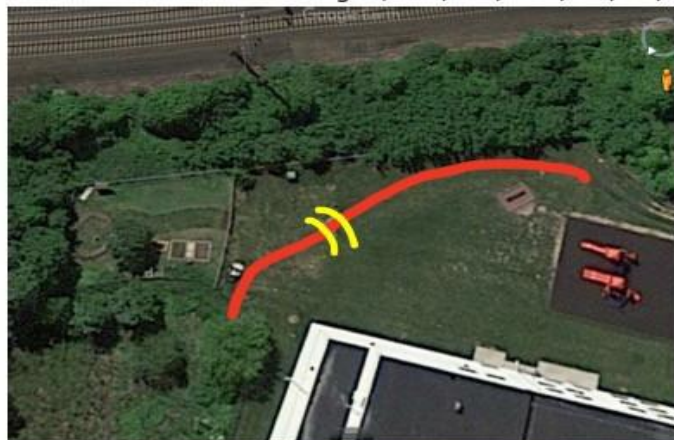

The red line represents the drainage ditch, and the yellow represents where I intend to build the bridge



Mallard Lodge



ESSP – Giving Leadership

- ✿ **How many people will you need to help?**
- ✿ **How will you recruit the workers for your project?**
- ✿ **What will be most difficult about leading those who are helping?**
- ✿ **What leadership skills will be important?**



ESSP – Materials.

Supplies and Tools

- ✦ **Materials (Stuff used and left behind)**
- ✦ **Supplies (Stuff used up)**
- ✦ **Tools (Equipment used to complete the project)**

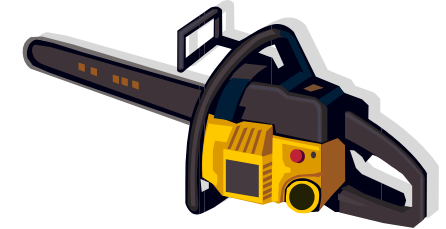
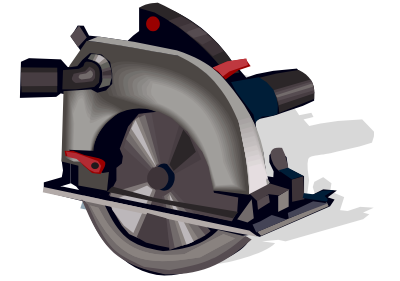

All three lists should

- ✦ **These are general lists of items needed to meet the project goals**
- ✦ **Be as thorough as you can, does not have to be 100% complete but must show good thought**
- ✦ **Does not require detail research for material quantities.**
- ✦ **Lists should coincide with safety issues (ie. Dehydration, include water, Power tools, include eye, ear, lung, and hand protection)**



ESSP – Permits, Cost and Funding Project

✦ **Permits and Permissions**

- ✦ **Some projects will require permission beyond that which the beneficiary provides such as building permits or Miss Utility. Indicate these and be sure to allow plenty of extra time to obtain these.**

✦ **Preliminary Cost Estimates**

- ✦ **Will need to do some research to estimate the cost of Materials, Supplies, Tools, and miscellaneous. Do not just make guesses! NOTE: Lumber and many building supplies have gone up significantly over the last several years! Also, some supplies may be in short supply!!! Seek out contractors for used or surplus materials!**
- ✦ **Should only be considered for things that will be consumed by the project (don't estimate costs for tools you will borrow).**

✦ **Fund Raising**

- ✦ **Explain with some details how you plan to raise the money for the project.**
- ✦ **Think of fundraisers that have leadership opportunities.**
- ✦ **The Fundraising Application is part of the approved project and must be completed if criteria are met.**
- ✦ **Remember that a Scout is Thrifty**



ESSP – Phases and Logistics

❖ Project Phases

- ❖ **These are the major steps you will make in completing your entire project from start to finish. Some phases could include:**
 - ❖ **Complete the final detailed plan**
 - ❖ **Submit the fundraiser application – (have a plan to make the fundraiser successful!)**
 - ❖ **Fundraiser**
 - ❖ **Purchase and deliver materials**
 - ❖ **Contact Miss Utility**
 - ❖ **Complete the fundraiser and project**
 - ❖ **Complete the project workbook**
 - ❖ **Send thank you's to those that made my project a success**

❖ Logistics

- ❖ **This section explains the plan for how all the project resources will be moved and possibly stored during your project. Other logistics could be the removal of dirt, grass or branches, or the location of nearest bathrooms or electricity.**



ESSP – Safety and Further Planning

✦ Safety Issues

- ✦ **List as many potential safety hazards and concerns as you can think of in this section. (Include required items in the Tools, Supplies and Materials sections). Some examples are: Dehydration, Splinters, Hitting fingers with hammers, Puncture wounds, Lacerations, Poisonous plants, electrocution, debris in eyes, loud noise, blisters, etc.. Make sure to check and reference *The Guide for Safe Scouting* to make sure that jobs and equipment are age-appropriate!**

✦ Further Planning

- ✦ **These are the steps you plan to take in completing your detail plan - NOT the steps needed to execute the plan.**
- ✦ **Examples: Investigate the best paint for cement blocks outdoors, create a detailed materials list, detailed drawings, determine the best flowers or grass for the area with full sunlight, etc....**



ESSP – Signatures

✦ Signatures

✦ **The candidate signs commitment (read before you sign).**

✦ **Confirms that he or she has read the entire ESSPW**

✦ **Candidate will lead the project**

✦ **Candidate will do his or her BEST to carry it out for MAXIMUM benefit to the religious institution, school, or community chosen as the beneficiary**

✦ **Unit Leader**

✦ **Unit Committee**

✦ **Beneficiary – Also confirms that they received a copy of “Navigating the Eagle Scout Service Project, Information for Project Beneficiaries”**

✦ **Last → Blue Hen District Eagle Chair**



ESSP – Signature Page!

 **The signature page needs to have all signatures, but the district signature, before district approval sign off.**

Candidate's Promise*		<i>Sign below before you seek the other approvals for your proposal.</i>	
On my honor as a Scout, I have read this entire workbook, including the "Message to Scouts and Parents or Guardians" on page 4. I promise to be the leader of this project, and to do my best to carry it out for the maximum benefit to the religious institution, school, or community I have chose as beneficiary.			
Signed		Date	

Make sure YOU sign!

** Remember: Do not begin any work on your project, or raise any money, or obtain any materials, until your project has been approved.*

Unit Leader Approval*		Unit Committee Approval*	
I have reviewed this proposal and discussed it with the candidate. I believe it provides impact worthy of an Eagle Scout service project, and will involve planning, development and leadership. I am comfortable the Scout understands what to do, and how to lead the effort. I will see that the project is monitored, and that adults or others present will not overshadow him.		This Eagle Scout candidate is a Life Scout, and registered in our unit. I have reviewed this proposal, I am comfortable the project is feasible, and I will do everything I can see that our unit measures up to the level of support we have agreed to provide (if any). I certify that I have been authorized by our unit committee to provide its approval for this proposal.	
Signed	Date	Signed	Date
Name (Printed)		Name (Printed)	

Make sure Beneficiary signature and check box for "Navigating...." is complete!

Beneficiary Approval*		Council or District Approval	
This service project will provide significant benefit, and we will do all we can to see it through. We realize funding on our part is not required, but we have informed the Scout of the financial support (if any) to which we have agreed. We understand any fund raising the Scout conducts will be in our name and that funds left over will come to us if we are allowed to accept them. We will provide receipts to donors as required.		I have read topics 9.0.2.0 through 9.0.2.10 regarding the Eagle Scout service project in the <i>Guide to Advancement</i> , No. 33088. I agree on my honor to apply the procedures as written, and in compliance with the policy on "Unauthorized Changes to Advancement." Accordingly, I approve this proposal. I will encourage the candidate to prepare a project plan and share it with the designated project coach.	
Our Eagle Candidate has provided us a copy of "Navigating the Eagle Scout Service Project, Information for Project Beneficiaries." Yes <input checked="" type="checkbox"/> No <input type="checkbox"/>			
Signed	Date	Signed	Date
Name (Printed)		Name (Printed)	

** While it makes sense to obtain approvals in the order they appear, there shall be no required sequence for the order of obtaining those approvals marked with an asterisk (*). Council or district approval, however, must come after the others.*



ESSP – How to Submit your Proposal – Blue Hen District North

Submit the Project Proposal directly to the Blue Hen North District Eagle Chair via email:

- 1. Blue Hen North – Andy Sensing
(asensing@aol.com)**

The proposal should be submitted as a .pdf file attached to an email. Copy your Scoutmaster and Eagle Mentor. The signed signature page must accompany the proposal. All pictures, diagrams, maps, and other attachments must be included. Pictures should have captions.



ESSP – How to Submit your Proposal – Blue Hen District South

- ❖ **1) Send an email notice to the Blue Hen South Eagle Board Chair that you are ready to submit your Eagle proposal. Mr. White - 70Eagle279@gmail.com. (Note you should cc your SM and mentor. All emails require at least one additional adult to comply with Youth Protection Requirements!). Body of the email should be written using proper etiquette and include a brief introduction of the candidate**
- ❖ **2) Mr. White will send you an invitation to setup a free cloud storage account on www.mega.nz This email will come from directly from mega.nz. (Your cloud account is free and will be yours to use even after your project is approved. However the access to your project folder will be deleted once the approval has been made.)**
- ❖ **3) After you have setup your account you will need to accept Mr. White's invitation to share your folder on the cloud server.**
- ❖ **4) After you have accepted the invitation notify Mr. White and he will send you a link to your folder.**
- ❖ **5) You will then be able to upload all the required documents necessary for the review and approval of your project.**



ESSP – Required Proposal Documentation

- ✦ **Submitted documents must include the following:**
 - ✦ **One ORIGINAL ESSP Workbook pdf file (not a scan). This should be the newest version – 2023a downloaded from Scouting.org.**
 - ✦ **Note: We will not accept the older versions due to software incompatibilities with certain versions!**
 - ✦ **One scan of Signature page (proposal page E) with **all** signatures, except the one for District Approval.**
 - ✦ **You need to provide a copy of “Navigating the Eagle Scout Service Project, Information for Project Beneficiaries.” and they need to check the block that they received it.**
 - ✦ **Optional – Additional pages with photos, drawings, diagrams, illustrations, etc. of locations and items you may build for your project.**



ESSP – District Review/Approval

✦ District Eagle Board Chair Approval

- ✦ Is the Community Benefit within guidelines?**
- ✦ Is the Leadership Opportunity commensurate with the rank of Eagle?**
- ✦ Does the candidate know how he or she will complete the detail plan?**
- ✦ May/Often need more information to complete approval – allow 2-4 weeks for the entire process, duration usually depends on response times.**
- ✦ You may be asked to make corrections or additions and resubmit before final approval is given.**

✦ Approval is typically communicated by email & will include

- ✦ Official notice of approval**
- ✦ Scan of signature sheet**
- ✦ Recommendations for detail planning**
- ✦ Directions for completing the Eagle Rank application process**
- ✦ Keep a copy of this for your Eagle Application**



ESSP – Items often overlooked in the proposal

- ❖ **Contact sheet - empty boxes – all need to be filled in, including Scout ID (PID) and Life BOR date, beneficiary information.....**
- ❖ **If you are doing construction, landscaping, remodeling – please include diagrams, plans, and if outside, maps. Maps should show be close to scale and include buildings, roads, landmarks, etc. Use of marked up Googlemaps or similar are acceptable. Pictures should have captions.**
- ❖ **Photos of the current location are helpful for the reviewers to better understand the state of the project area. Using a person as reference in a photo is helpful to gauge size, height and distance.**
- ❖ **If moving or removing material during the project, explain what you plan to do with it – dirt, grass, old structures – fence picnic tables, shed, etc.**
- ❖ **The signature page needs to have all signatures, but the district signature, before district approval sign off.**



ESSP – Final Plan

ESSPW – Final Plan pages A to E

- ❖ **Responsibility for completing the “Eagle Scout Service Project Plan” (Detail Plan) section of the workbook**
 - ❖ **The Eagle Candidate is responsible for completing the Project Workbook.**
 - ❖ **The Unit Committee & Mentor is responsible for guiding and supporting the candidate (safety, quality, technical aspects).**
- ❖ **Timing of completing the Detail Plan**
 - ❖ **Can start anytime but don't put too much effort in prior to approval.**
 - ❖ **Is to be complete BEFORE starting work on the project.**
 - ❖ **Once complete, or nearly complete, share the plan with the Eagle mentor for review and input**
 - ❖ **The plan is not submitted to the Eagle Board Chair for approval.**



ESSP – Fundraising Application

Workbook – Fundraising Application pages A and B

- ✿ **All fundraising activities require prior approval.** The Eagle Scout Service Project Fundraising Application must be used to obtain approval for raising money for the service project or securing donations or discounts of materials and supplies.
- ✿ **The Fundraising Application is not necessary for contributions from the candidate, the candidate's parents or relatives, the unit or its chartered organization, unit's parents or members, or the beneficiary. All proceeds left over from fundraising or donations, whether money, materials, supplies, etc., regardless of the source, go to the beneficiary.**
- ✿ **The Fundraising Application, with beneficiary and unit leader signatures, should be submitted for approval to the Eagle Board of Review Chair along with the project proposal.**
- ✿ **Consider whether your fundraising project will be a major portion of the demonstration of your leadership. Please reference the Fundraising Application Page B in the project workbook.**



ESSP - Finishing the Job

Execute the Plan & Complete the ESSP workbook

- ✿ **YOU lead others to accomplish the project goals**
- ✿ **YOU are responsible for safe working conditions**
- ✿ **YOU track work progress, hours worked, money spent, etc.**
- ✿ **YOU develop solutions to unforeseen challenges**
- ✿ **YOU record changes made to the plan including**
 - ✿ **why the change was made**
 - ✿ **how the solution was decided**
- ✿ **Record worker hours – Including Fundraising**
- ✿ **Thank all of those people, groups or businesses that made your project successful.**





ESSP – Eagle Board Assistance

- **The Eagle Board is always available to answer questions and provide input and/or assistance as needed for your project.**

One of our goals is to make sure you have the tools to be successful!

- **A representative from the Eagle Board can be available for meetings with you and your mentor via:**
 - Zoom
 - Conference Calls
 - In Person meetings

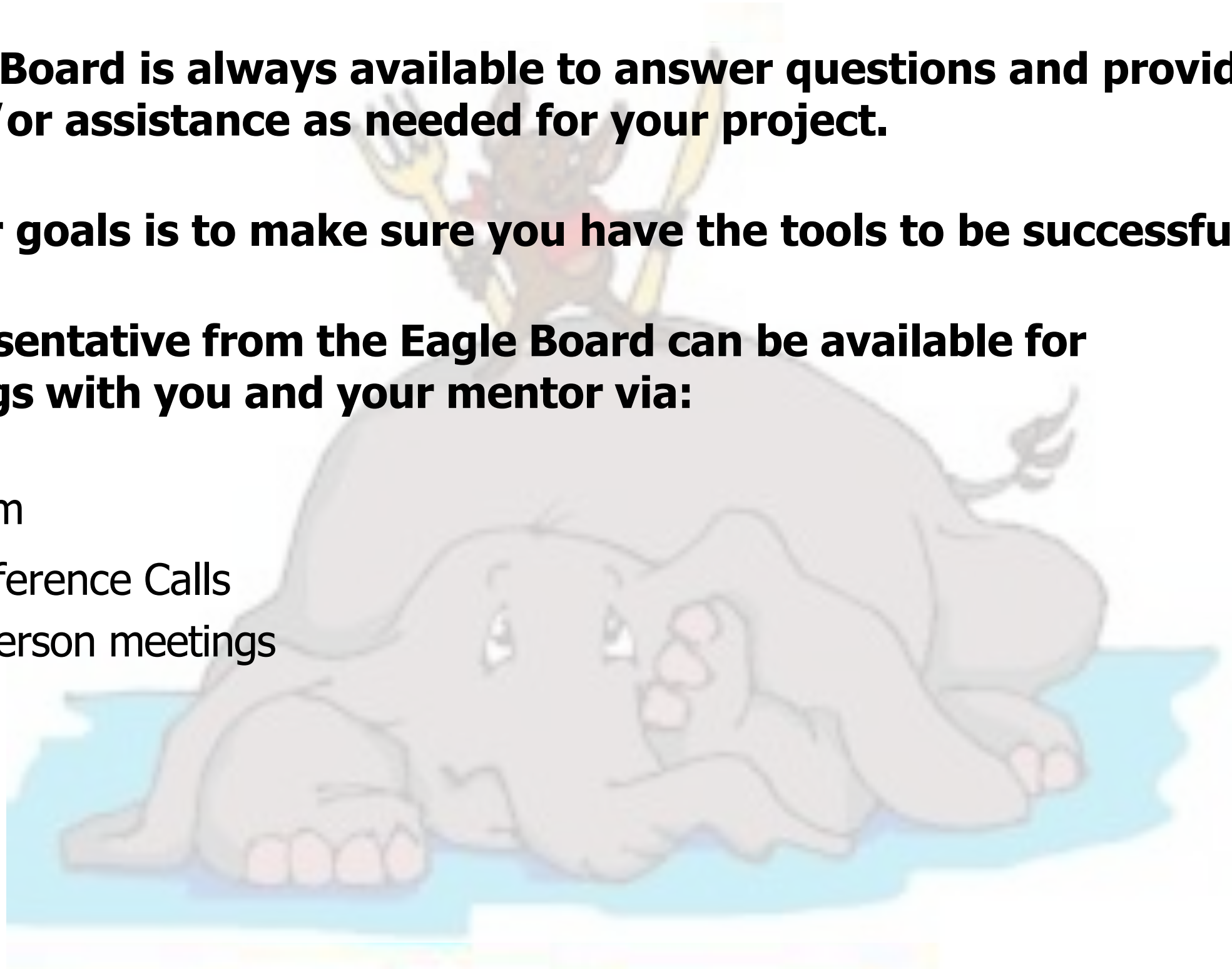



ESSP – Project Report

- **Project completion date is when the project was completed (not when workbook is completed)**
- **Workbook must be completed before Eagle Application**
- **Changes**
- **Leadership demonstrated**
- **Hours you spent planning**
- **Hours you spent carrying out the project**
- **Hours others spent working on the project**
- **Materials (and funds) required to complete project**
- **“After” Photographs of the completed project**
- **Signatures**
 - Eagle candidate signs and dates after completion**
 - Representative of beneficiary organization**
 - Scoutmaster/Coach/Advisor**



Intermission!





Requirement 6. ULC

Take part in a unit leader conference.

- ❖ **This is the final opportunity for the Unit Leader to review and “test” YOUR readiness for the Rank of Eagle**
- ❖ **It must be completed prior to YOUR 18th birthday**





Requirement 6. *Statement of Ambitions and Life Purpose*

- ❖ **Attach to the Eagle application a statement of your ambitions and life purpose and a listing of positions held in your school, camp, community, or other organizations during which you demonstrated leadership skills, including honors & awards received.**
- ❖ **Your *Statement of Ambitions and Life Purpose* is your opportunity to tell the Eagle Board what you view as your goals for *the future!* This may include if you plan to seek higher education, attend trade school, go into the military, pursue public service, etc. It may describe how you see or plan your life in the next 5, 10, or more years for a career, a family, community activities, travel, and involvement in Scouting.**
- ❖ **You may include your background in Scouting and how it has prepared you for your future but it is not a look back on your past and all the things you did as a Scout. It is your vision of how you see your future and what you intend to do to make it happen!**



Eagle Rank Application Process

- ✦ **Complete Application requirements 1-6. (Note this includes references supplied by persons in requirement #2!)**
- ✦ **Assemble Eagle Rank Application Packet (This is the 21st century – use a computer. No hand-written applications!)**
- ✦ **Complete the Unit Leader Conference**
- ✦ **Obtain final unit signatures on the application**
- ✦ **Submit a copy to the Council Registrar via email.**
- ✦ **EMAIL packet to Ms. Carol Swank, Council Registrar (cswank@delmarvacouncil.org) as pdf files.**
- ✦ **Copy the District Eagle Chair on the email to Ms. Swank.**



Eagle Rank Application Process

Your Application documentation should include:

- ✦ **The Eagle Rank Application - checked for errors. Latest version is January, 2026**
- ✦ **Copies of the Individual Progress, Individual History, and the Individual Participation reports from TroopMaster, or Scoutbook.**
- ✦ **Your project approval email you received from the district allowing you to proceed. Also, include all additional communications you may have received from the District committee.**
- ✦ **The complete Eagle Scout Service Project workbook (ESSPW) with required signatures. Extra pictures, receipts, flyers, thank you letters, and planning documents that you used can and should also be included**
- ✦ **Your *Statement of Life Ambitions and Goals and Extra-Scouting Leadership and Honors***



Eagle Rank Application Process

- ✦ **At least 6 months after Life Board of Review**
- ✦ **Dates of Requirements 4 and 5 (position of responsibility and service project) must be on or before date of Scoutmaster conference (Requirement 6)**
- ✦ **Date of Final Project signature (Requirement 5) matches the date on Workbook**
- ✦ **Date of Applicant's Signature is after Requirement 6 and before Unit Approval. Signature of unit leaders in any order, but after conference**
- ✦ **All signatures before applicant's 18 birthday**



Eagle Rank Application Process

Reference Letters

- ❖ **List the names and contact information for four people who know you personally and would be willing to write a letter of recommendation on your behalf.**
 - ❖ These may be Scout leaders, teachers, employers, coaches, other Scouts, etc. Parents and other relatives are strongly discouraged from serving as references. The current unit leader and committee chair are not eligible to serve as references. References do not need to be 21 or older.
 - ❖ Some units provide a form letter explaining the purpose of the recommendation, the qualifications and requirements for Eagle, and where recommendations should be sent.
 - ❖ The troop should have a process for collecting and submitting the letters. Most troops have the letters sent to the Unit Leader or Unit Advancement Chair and they are then forwarded to the District Eagle Board Chair. Letters should not be sent/given to the Eagle candidate. The Scout may assist with any contacts that do not respond but it is the responsibility of the unit to follow-up, not the Scout's.



Eagle Rank Application Process

Reference Letters

- ✿ **Written reference letters are to be submitted to the Eagle Board Chair separately by your Scoutmaster or Advancement Chair.**
- ✿ **The Scout is responsible for requesting references from the four people listed on the Eagle application. This is a valuable life skill.**
- ✿ **If the required references are not listed on the application, Mrs. Swank will return the application for revision.**
- ✿ **Note that an Eagle Board of Review committee member may contact these people for additional information.**

REQUIREMENT 2. As a Life Scout, demonstrate that you live by the principles of the Scout Oath and Scout Law in your everyday life and tell how you have done your duty to God. List the names of individuals who know you personally and would be willing to provide a recommendation on your behalf.

	Name	Address (including City, State, Zip)	Telephone	Email
#1				
#2				
#3				
#4				



Eagle Rank Application Process

Reference Letters

- ❖ **Reference letters should be sent directly to the Eagle Board of Review Chair**
- ❖ **A Scout cannot have a Board of Review denied or postponed because the District Eagle Chair does not receive letters of recommendation.**
- ❖ **If no letters are received, the Scoutmaster will be contacted prior to the Board of Review.**

Recommendation letters are confidential, and their contents are not to be disclosed to any person who is not a member of the Board of Review.



Requirement 7. Successfully Complete an Eagle Board of Review

- ✿ **When the completed application is received at the council service center its contents will be verified by the Registrar.**
- ✿ **Any issues will be resolved by the Council Registrar working with the Scoutmaster and Eagle candidate.**
- ✿ **After the contents of an application have been verified and appropriately signed by the Council Registrar, the Eagle Application Packet will be transferred to the District Eagle Board Chair so that a Board of Review may be scheduled.**
- ✿ **A Board of Review will not be scheduled until the application packet is received by the chair of the Eagle Board of Review.**



Requirement 7. Successfully Complete an Eagle Board of Review

- ✦ **Registrar validates application, confirms that all information is included and notifies Eagle Board Chair to schedule the Eagle Board of Review.**
- ✦ **Eagle Board is scheduled with the Candidate by the Eagle Board Chair**
- ✦ **Conduct Board of Review (Board make-up may vary between Districts).**
- ✦ **Make sure to look your best for your Eagle Board of Review!**
 - ✦ **Wear your sash with all merit badges**
 - ✦ **You should have all current rank and other patches on your uniform.**
 - ✦ **Wear any Scout awards, medals, knots, etc.**
 - ✦ **Bring your Scoutbook to be signed by the Board members**
- ✦ **Council Scout Executive Approval.**
- ✦ **National approval.**
- ✦ **Award materials are available 4-6 weeks after Eagle Board of Review is complete.**
- ✦ **Troop/Crew Conducts Eagle Court of Honor.**



Eagle Board of Review

Scheduling

❖ Our goal is to schedule all Boards within four to six weeks after receiving the packet from Council. This enables the Eagle Board Chair to manage the queue and allows the Board time to contact references, read the packet, and visit the project site, if desired.

❖ The candidate and Scoutmaster are notified by email of the date, time, and location of the Eagle Scout Board of Review.

If you must reschedule, contact the Eagle Board Chair immediately.

❖ Eagle Boards in Northern Blue Hen District:

Eagle Scout Boards of Review are usually held on Sunday evening; up to twice each month

❖ Eagle Boards in Southern Blue Hen District

Eagle Scout Boards of Review are usually held on the second and fourth Monday evenings





Eagle Board of Review

Purpose

- ✿ **The Eagle Board of Review will review and approve the manner in which the Eagle Scout Service Project was carried out.**
- ✿ **The Board will review the candidate's participation in the Scouting program, the statement of ambitions and life purpose, and demonstrations of leadership and the Scout Oath and Law outside of Scouting.**
- ✿ **The Board will consider how well the candidate will represent the values and fulfill the responsibilities of an Eagle Scout.**
- ✿ **The Scout should bring a hard copy of the Eagle application packet and the Scout Handbook to the Board of Review.**



What to expect in your Eagle Board of Review

- ✦ **The Board will last approximately 45 minutes to 1 hour. This will be an in-person board. Zoom is optional but not recommended unless the Scout cannot attend at the designated location.**
- ✦ **The board will consist of approximately 3-5 adult Scouters from Blue Hen District and may include a member of your troop committee. Your Scoutmaster will also be in attendance but only to act as your advocate and for support and will not participate in the Review. No other individuals will be allowed to attend the Board session until a decision on your application is made.**
- ✦ **During your board you will be asked a number of questions of which there is no right or wrong answer. Some will be questions of your Scouting history, some will be about your thoughts of the Scouting program, The Scout Law, Scout Oath, etc., and there will be questions about your project.**
- ✦ **Following the interview period the Board will meet without the candidate or Scoutmaster and will determine whether the candidate passed the Board. The decision must be unanimous.**



Examples of Board Questions

- ✦ **There is no specific set of questions that an Eagle candidate should be asked.**
- ✦ **There are no right or wrong answers, but simple yes and no answers are rarely sufficient. A thorough discussion of the candidate's successes and experiences in Scouting should be considered.**
- ✦ **Tell us what merit badge you learned the most?**
- ✦ **What was your favorite experience in your Troop?**
- ✦ **What is your style of leadership?**
- ✦ **What is your favorite meal to cook on a campout, and why?**
- ✦ **What would you change about the Scouting program if you could?**
- ✦ **How do you deal with leading Scouts that are older than you, younger than you?**
- ✦ **What does "Duty to God" mean to you?**



Eagle Board of Review

Decision

- ✿ **When the Board's deliberations are complete, the candidate is asked to return.**
- ✿ **If the Board of Review was acceptable, the candidate is informed of the Board's decision to recommend award of the Eagle Scout rank.**
- ✿ **If the candidate does not meet the requirements, the candidate is told the reasons for failure to qualify. A discussion will be held as to how the requirements may be met within a given period and the Board of Review will be adjourned until then. Should the applicant disagree with the decision, the appeal procedures should be explained.**



Eagle Application Council Review

- ✿ **After the Board of Review and after the application has been appropriately signed, the signed Eagle Application is returned to the council service center.**
- ✿ **When the application arrives at the Council service center, the Scout executive signs it to certify that the proper procedure has been followed and that the Board of Review has recommended the candidate for the Eagle Scout rank.**
- ✿ **Only the Eagle Scout Rank Application is forwarded to the national Eagle Scout Service.**



Eagle Application Review by National



- ❖ **The Eagle Scout Service screens the application.**
- ❖ **Any item not meeting national standards will cause the application to be returned for more information.**
- ❖ **Eagle Scout certificate is sent to the local council. The date used on the certificate will be the date of the Board of Review. The Eagle Scout Court of Honor should not be scheduled until the local council receives the Eagle Scout rank credentials.**
- ❖ **The Eagle patch, medal and pins may be purchased from the Council Scout Shop.**
- ❖ **After earning the Eagle Scout Award, a Scout may work to earn Eagle Palms before the Scout's 18th birthday. Palms must be earned one at a time, in the order of Bronze, Gold, and then Silver.**



Eagle Rank Resources

Website URL – Subject to Change

✿ **Eagle Scout Service Project Workbook and Procedures.**

<http://www.scouting.org/programs/scouts=bsa/advancement-and-awards/eagle-scout-workbook/>

✿ **Eagle Application (PDF). (Jan 2026 rev.)**

https://www.scouting.org/wp-content/uploads/2026/02/512-728_26-Eagle-Scout-Application_WEB.pdf

✿ **Guide to Safe Scouting.**

<http://www.scouting.org/scoutsource/HealthandSafety/GSS.aspx>

✿ **Guide to Advancement. *New for 2025***

<http://www.scouting.org/scoutsource/GuideToAdvancement.aspx>

✿ **Age Guidelines for Tool Use and Work at Elevations or Excavations.**

<http://www.scouting.org/filestore/healthsafety/pdf/680-028.pdf>



Everything you need to know is in:

- Boy Scout Handbook
- Eagle Scout Service Project Workbook
- Eagle Scout Rank Application

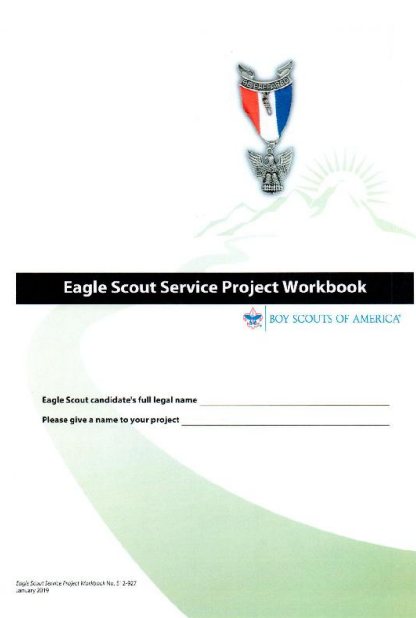



Extension Requests

- ✿ If a Scout foresees that due to no fault or choice of his or her own, it will be impossible to complete the Eagle Scout rank requirements before age 18 may apply to the local council for a limited time extension. These should be granted only when necessary and are reserved only for work on Eagle. In most cases, unless the National Council has issued other direction, a request must meet the three tests listed below to be approved.
 - ✿ **Test #1:** The member joined or rejoined (or became active again after a period of inactivity, or became refocused on advancement after a period of inattention) in time to complete all requirements before turning 18.
 - ✿ **Test #2:** Through no fault or choice of the Scout, an unforeseen circumstance or life changing event with severe consequences has come to exist that now precludes completion of the requirements before the deadline.
 - ✿ **Test #3:** The circumstance is beyond the control of the Scout, could not have been anticipated or planned for, and was not or cannot be resolved in time to complete the requirements.
- ✿ **Extensions are never guaranteed! Extensions are only approved in emergency circumstances as noted above. DO NOT RELY on an EXTENSION!**



Discussion & Questions

